

UNCONTROLLED DOCUMENT

PART NUMBER		REV.
SSP-1157B156U12		B
REV.	E.C.N. NUMBER AND REVISION COMMENTS	DATE
A	E.C.N. #10986.	5.8.03
B	E.C.N. #11025.	8.19.03

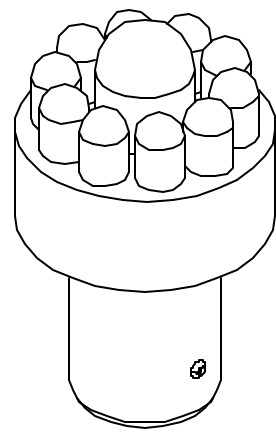
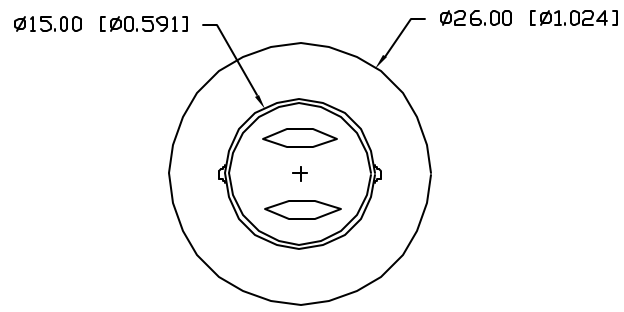

ELECTRO-OPTICAL CHARACTERISTICS $T_A=25^{\circ}\text{C}$ $V_f=12\text{V}$

PARAMETER	MIN	TYP	MAX	UNITS	TEST COND
PEAK WAVELENGTH		626		nm	
FORWARD VOLTAGE		12.0	14.0	V_f	
REVERSE VOLTAGE	5.0			V_r	$I_r=100\mu\text{A}$
AXIAL INTENSITY*		47/15.6		cd	$V_f=12\text{V}$
VIEWING ANGLE		30		2x theta	
EMITTED COLOR:	RED				
EPOXY LENS FINISH:	WATER CLEAR				

*STOP/RUN

LIMITS OF SAFE OPERATION AT 25°C PER MODULE

PARAMETER	MAX	UNITS
PEAK FORWARD VOLTAGE	14	V
STEADY CURRENT	80	mA
POWER DISSIPATION	105	mW
DERATE FROM 25°C	-1.2	mW/°C
OPERATING, STORAGE TEMP.	-40 TO +85	°C

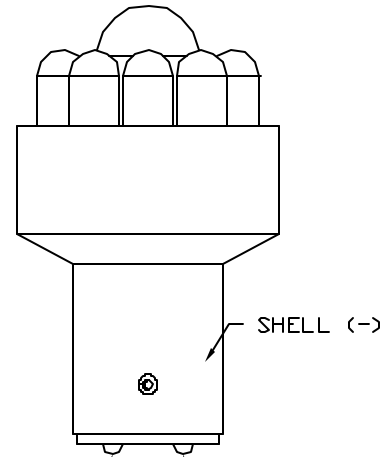
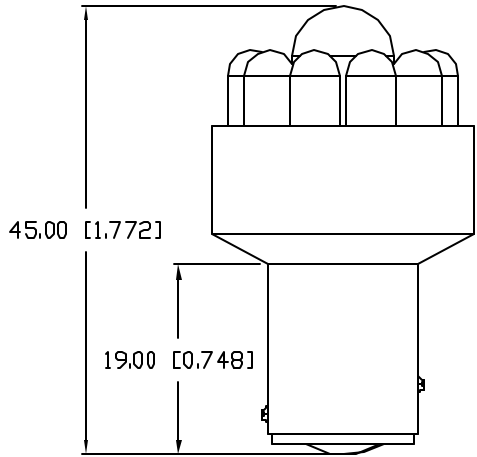

TAIL LIGHT (+) BRAKE LIGHT (+)

*UNLESS OTHERWISE SPECIFIED TOLERANCES PER DECIMAL PRECISION ARE: X=±1 (±0.039), X.X=±0.5 (±0.020), X.XX=±0.25 (±0.010), X.XXX=±0.127 (±0.005). LEAD SIZE=±0.05 (±0.002), LEAD LENGTH=±0.75 (±0.030). MIN. ^{+DECIMAL PRECISION} -0.00 ^{MAX.= +0.00} -DECIMAL PRECISION

UNCONTROLLED DOCUMENT

REV.	PART NUMBER
B	SSP-1157B156U12
1157 LED REPLACEMENT LAMP, RED.	

CONFIDENTIAL INFORMATION
 THE INFORMATION CONTAINED IN THIS DOCUMENT IS THE PROPERTY OF SUNBRITE LEDS. EXCEPT AS SPECIFICALLY AUTHORIZED IN WRITING BY SUNBRITE LEDS, THE HOLDER OF THIS DOCUMENT SHALL KEEP ALL INFORMATION CONTAINED HEREIN CONFIDENTIAL AND SHALL PROTECT SAME IN WHOLE OR IN PART FROM DISCLOSURE AND DISSEMINATION TO ALL THIRD PARTIES.

RELIABILITY NOTE
 OUR MANY YEARS OF EXPERIENCE DATA ACCUMULATION INDICATE THAT SOLDER HEAT IS A MAJOR CAUSE OF EARLY AND FUTURE FAILURE. PLEASE PAY ATTENTION TO YOUR SOLDERING PROCESS.

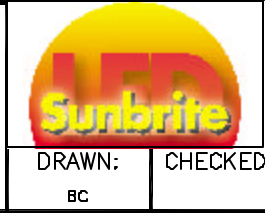

286 E. HELEN ROAD PALATINE, IL 60067-6976 PHONE: +1.847.348.3116 FAX: +1.847.359.2887 WEB: www.sunbriteleds.com	
DRAWN:	CHECKED:
APPROVED:	DATE: 5.6.02
BC	PAGE: 1 OF 1